



# NAPCO GEM-PIRPET Wireless Pet Immune PIR Transmitter

333 Bayview Avenue  
Amityville, New York 11701  
For Sales and Repairs, (800) 645-9445  
For Technical Service, (800) 645-9440  
Publicly traded on NASDAQ Symbol: NSSC

© NAPCO 2006

WI1029A 5/06

## GENERAL DESCRIPTION

The GEM-PIR is an advanced Pet Immune PIR sensor designed for use with NAPCO's GEM-Series wireless receivers. In normal operation, the GEM-PIRPET will avoid detection of pets up to 40 lbs. total weight or 24" tall. The unit is powered by two 3-volt lithium batteries (supplied) for long service life. When battery voltage drops below normal, a low-battery report will be sent to the receiver. (replace with Duracell DL123A or Varta/Power-One CR123A only). Coding switches are not used in the GEM-PIRPET. Each transmitter has a unique factory-programmed RF ID code (printed on the unit) that distinguishes itself to the receiver. (Note: See control-panel instructions for enrolling the GEM-PIRPET into the panel).

## SPECIFICATIONS

PIR Coverage (l x w): 50' x 50' (15.2m x 15.2m) at 20°C (68°F), typical.

Operating Temperature: 0° to +50°C (32° to 122°F)

Mounting: Wall or Corner

Recommended Mounting Height : 7' typical

Dimensions: 4.5"x2.5"x1.7" (11.4cm x 6.4cm x 4.3cm)(HxWxD)

Shipping Weight: 6.4oz (181gm)

## FEATURES

- Signal Selective Processing for reliable operation
- Unique circuit design protects against false alarms due to radio-frequency interference
- Vertical and horizontal aiming capabilities
- Dual-element sensor
- Stacked Array Pattern Lens for optimum pet avoidance
- Small size with ample wiring space
- Corner mountable
- Built-in Tamper microswitch

## Locating the Detector

Corner mounting with this lens is preferred as it provides the best overall coverage. Choose a corner where the path of an intruder will most likely cross beams, as opposed to walking towards or away from them. This lens is intentionally made with an 85 degree angle of view, to help prevent curtains on windows from being in detection zones.

Sources of heat, such as radiators and space heaters, do not usually pose a problem as long as hot air from them does not *blow directly* onto the detector. One exception to this is overhead radiant heaters, these produce very high levels of infrared energy and can heat the unit at some distance. Mount the unit as far from these as possible. Do not mount the unit where the sun can shine directly on it. Mount it away from the direction of sunlight.

## Installations with Pets

The GEM-PIRPET will provide good immunity to small pets (no larger than 40 lbs. total weight or 24" tall). Locate the detector at a height of 7 ft. and avoid placement that would allow the pets to get within 6 ft. of the detector. It may be necessary to mask a zone of the lens with the supplied material if a staircase is closer than 20 ft. to the detector and directly in a zone. Set the Operating Mode for SSP operation.

NOTE: Pet Immunity has not been evaluated by UL.

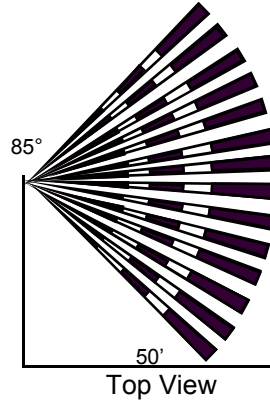

## Protection Pattern

(SSP Mode Jumper ON for Pet Applications)

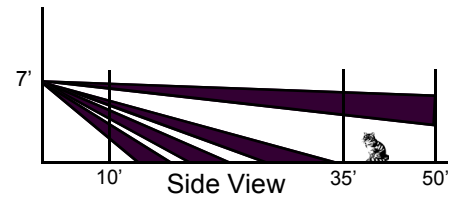

NOTE: The LENS LN115 supplied with the GEM-PIRPET must be used in order to achieve Pet Immunity. Do not replace the lens with another from the Lens Library.

## Walk Testing

The GEM-PIRPET has an LED which will light to indicate activity in the Walk-Test Mode only. After power-up, allow at least 3 minutes for the unit to settle before testing. Press the Walk-Test Button to initiate a 5 minute Walk-Test Mode. Replace the cover and then walk out to the maximum range and across the field of coverage. The LED will light whenever motion is detected and a zone violation will be transmitted to the control panel. Check for environmental disturbances with all disruptive devices (heaters, air conditioners) on and no human activity within the coverage area. Adjust beams laterally by removing the Lens Support and sliding the lens slightly left or right. To block a problem zone, apply a piece of lens foil (supplied) to the inside segment of the lens representing that zone.

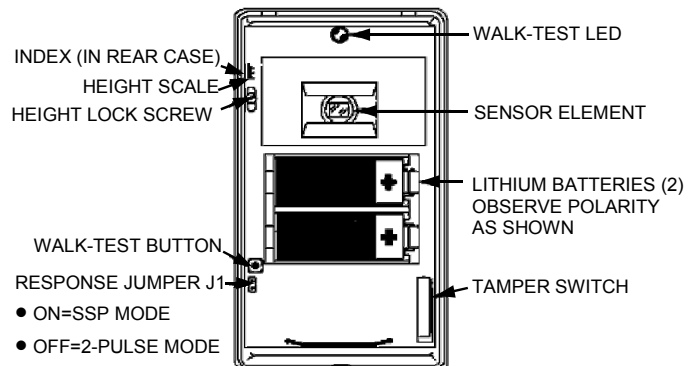

## Setting The Operating Mode

The GEM-PIRPET is configured for default operation in the Signal Selective Processing (SSP) Mode. To change to the fixed 2-pulse bipolar mode for use in a non-pet application, remove the Response Jumper, J1.

# NAPCO LIMITED WARRANTY

NAPCO SECURITY SYSTEMS, INC. (NAPCO) warrants its products to be free from manufacturing defects in materials and workmanship for *thirty-six months* following the date of manufacture. NAPCO will, within said period, at its option, repair or replace any product failing to operate correctly without charge to the original purchaser or user.

This warranty shall not apply to any equipment, or any part thereof, which has been repaired by others, improperly installed, improperly used, abused, altered, damaged, subjected to acts of God, or on which any serial numbers have been altered, defaced or removed. Seller will not be responsible for any dismantling or reinstallation charges.

THERE ARE NO WARRANTIES, EXPRESS OR IMPLIED, WHICH EXTEND BEYOND THE DESCRIPTION ON THE FACE HEREOF. THERE IS NO EXPRESS OR IMPLIED WARRANTY OF MERCHANTABILITY OR A WARRANTY OF FITNESS FOR A PARTICULAR PURPOSE. ADDITIONALLY, THIS WARRANTY IS IN LIEU OF ALL OTHER OBLIGATIONS OR LIABILITIES ON THE PART OF NAPCO.

Any action for breach of warranty, including but not limited to any implied warranty of merchantability, must be brought within the six months following the end of the warranty period.

IN NO CASE SHALL NAPCO BE LIABLE TO ANYONE FOR ANY CONSEQUENTIAL OR INCIDENTAL DAMAGES FOR BREACH OF THIS OR ANY OTHER WARRANTY, EXPRESS OR IMPLIED, EVEN IF THE LOSS OR DAMAGE IS CAUSED BY THE SELLER'S OWN NEGLIGENCE OR FAULT.

In case of defect, contact the security professional who installed and maintains your security system. In order to exercise the warranty, the product must be returned by the security professional, shipping costs prepaid and insured to NAPCO. After repair or replacement, NAPCO assumes the cost of returning products under warranty. NAPCO shall have no obligation under this warranty, or otherwise, if the product has been repaired by others, improperly installed, improperly used, abused, altered, damaged, subjected to accident, nuisance, flood, fire or acts of God, or on which any serial numbers have been altered, defaced or removed. NAPCO will not be responsible for any dismantling, reassembly or reinstallation charges.

This warranty contains the entire warranty. It is the sole warranty and any prior agreements or representations, whether oral or written, are either merged herein or are

expressly cancelled. NAPCO neither assumes, nor authorizes any other person purporting to act on its behalf to modify, to change, or to assume for it, any other warranty or liability concerning its products.

In no event shall NAPCO be liable for an amount in excess of NAPCO's original selling price of the product, for any loss or damage, whether direct, indirect, incidental, consequential, or otherwise arising out of any failure of the product. Seller's warranty, as hereinabove set forth, shall not be enlarged, diminished or affected by and no obligation or liability shall arise or grow out of Seller's rendering of technical advice or service in connection with Buyer's order of the goods furnished hereunder.

NAPCO RECOMMENDS THAT THE ENTIRE SYSTEM BE COMPLETELY TESTED WEEKLY.

**Warning:** Despite frequent testing, and due to, but not limited to, any or all of the following; criminal tampering, electrical or communications disruption, it is possible for the system to fail to perform as expected. NAPCO does not represent that the product/system may not be compromised or circumvented; or that the product or system will prevent any personal injury or property loss by burglary, robbery, fire or otherwise; nor that the product or system will in all cases provide adequate warning or protection. A properly installed and maintained alarm may only reduce risk of burglary, robbery, fire or otherwise but it is not insurance or a guarantee that these events will not occur. CONSEQUENTLY, SELLER SHALL HAVE NO LIABILITY FOR ANY PERSONAL INJURY, PROPERTY DAMAGE, OR OTHER LOSS BASED ON A CLAIM THE PRODUCT FAILED TO GIVE WARNING. Therefore, the installer should in turn advise the consumer to take any and all precautions for his or her safety including, but not limited to, fleeing the premises and calling police or fire department, in order to mitigate the possibilities of harm and/or damage.

NAPCO is not an insurer of either the property or safety of the user's family or employees, and limits its liability for any loss or damage including incidental or consequential damages to NAPCO's original selling price of the product regardless of the cause of such loss or damage.

Some states do not allow limitations on how long an implied warranty lasts or do not allow the exclusion or limitation of incidental or consequential damages, or differentiate in their treatment of limitations of liability for ordinary or gross negligence, so the above limitations or exclusions may not apply to you. This Warranty gives you specific legal rights and you may also have other rights which vary from state to state.