

# DSC

*From Tyco Security Products*



# Commercial Fire Monitoring Solutions

DSC -- The Most Trusted Name In Fire Monitoring



## Contents

1	Introduction
2	Product Features
3	Approval Information
4	Installation Information
5-6	Wiring Diagrams
7-9	Frequently Asked Questions
10-12	Appendix A: NFPA72 Compliance
13	Clarifications on NFPA72
13	Appendix B: UL Listing Guide



The increasing adoption of new technologies, such as cellular and IP communications and the shift away from plain old telephone lines (POTs), has led the National Fire Protection Association (NFPA) to expand and elaborate these new communication technologies to their latest standards of the NFPA72, 2010 Edition.

In order to meet the requirements of a communicator deployed for commercial fire applications, the standard has specified, among other things, that:

- communication paths must be monitored and any failure of the communication path shall be announced at the supervising station within 5 minutes of the failure
- the battery backup needs to provide 24 hours of standby current

DSC's 3G3070-CF and T-Link TL300/TL300CF are UL listed as sole path communication systems for fire control panel communications with cellular and IP communications respectively. In order to obtain this listing, these products were thoroughly tested as per the UL864 9th Edition and UL1610 Standards.

The IP alarm communicator models 3G3070-CF and T-Link TL300CF are FM approved for use as a single communication technology when the heartbeat supervision is enabled at the Supervising station compatible receiver. These communicators can also be used in a back-up configuration in conjunction with an approved DACT communicator.

The 3G3070-CF and the T-Link TL300/TL300CF can now be installed in certified installations in accordance with the requirements of UL827 Standard and NFPA72 2002 (Section 8.5.4 Other Transmission Technologies), NFPA72 2007 (Section 8.6.4 Other Transmission Technologies) or NFPA72 2010 Code (Section 26.6.3.1). Refer to 'Appendix A' for details for compliance with NFPA72 current edition.

The complete cellular and IP CF kits include 24 hour battery backup, power supply (powered from 120VAC connection), as well as supervision setup for fire applications. The standalone TL300/TL300CF can be powered directly off of any UL listed power supply rated from 12 VDC - 24 VDC. The 3G3070-CF is programmed using C24 Communications ([www.connect24.com](http://www.connect24.com)) and the TL300/TL300CF is programmed manually.

The 3G3070-CF and the TL300/TL300CF are compatible with listed alarm control panels that have an integrated Digital Alarm Communication Transmitter (DACT) and support a 4 or 10 digit Contact ID Communication Format. They are designed to work with the Contact ID communication format as described in SIA DC-05 Standard.

Alternatively, these units can also be setup solely with the dry contact outputs from the panel to the zone inputs of the communicators. Telephone lines over voltage protection and monitoring with automatic switch over to the cellular/IP network communication path when a phone line trouble condition exists are also provided. Please see following page for detailed product features on both communication systems.

## 3G3070-CF Product Features

- Compatible with control panels that communicate using Contact ID format
- Full event reporting
- Uses HSPA (3G) data channel for high-speed, reliable and low-cost communications to an IP receiver
- Automatically switches to 2G (EDGE/GPRS) if 3G service is not available
- 4 on-board inputs and 4 on-board outputs (open collector)
- SIM card (included)
- Activation and initialization via automated telephone activation system (VRU) or web-user interface provided by C24 Communications
- Compatible with Sur-Gard System I/II/III/IV monitoring station receivers
- Includes UL listed power supply, transformer and 7 Ah rechargeable battery
- 24 hour battery backup
- Transformer (120VAC) and Power Supply (PS4085)
- Ships with the PC4050CR Red Cabinet for Fire Applications
- 300 second Supervisory Window and programmable heartbeat intervals
- UL Commercial Fire listed, CSFM listed and NFPA72 compliant, FM approved, NYC Fire Dept. (back-up only)
- Cellular network connection and signal strength indicator

## TL300/TL300CF Product Features

- Compatible with most control panels that use the Contact ID format
- 2-way, always-on IP communication
- Works over local LAN/WAN network or the Internet
- 128-bit AES encryption (NIST approved)
- Supports DHCP (dynamic IP addresses)
- Reports events to 2 different receiver IP addresses
- Polling and hardware substitution protection
- Low network bandwidth requirements
- Compatible with 10/100BaseT networks
- Compatible with Sur-Gard System I/II/III/IV monitoring station receivers
- 4 on-board programmable zone inputs (expandable to 12 using PC5108 zone expander)
- 2 programmable voltage outputs
- Programmable through the panel keypad or T-Link Console software
- 24 hour battery backup
- Transformer (120VAC) and Power Supply (PS4085)
- Ships with the PC4050CR Red Cabinet for Fire Applications
- 300s Supervisory Window and programmable heartbeat intervals
- UL/ULC Commercial Fire listed, CSFM listed and NFPA72 compliant, FM approved

*Note: Before completing the field installation of the alarm monitoring system, ensure communication with the supervising station is successful by sending several events and getting confirmation that they have been received. Please contact your supervising station to review all of their requirements for onsite testing.*



## Approval Information

For Commercial Fire Monitoring Installations, the 3G3070-CF and the TL300/TL300CF can be used in the following configurations:

### 1. Sole communicator, single communication technology

- a. These installations require a 5 minute supervision window.
- b. By default, the 3G3070-CF sends heartbeats to the supervising station every 97 seconds and the TL300/TL300CF sends heartbeats every 10 seconds. These are programmable and may be changed by the installer if required.

### 2. Back-up communicator line for a DACT

- Alarm signals must first be sent over the primary communication path (DACT), however if this fails it must then be sent over the secondary communication paths (other transmission technologies).
- Primary: Compatible listed control unit's land line to supervising station.
- Secondary: 3G3070-CF transmission through the cellular network or TL300/TL300CF transmission through IP network to supervising station.
- Every 24 hours a check-in signal must be sent to the supervising station over the primary communication path. The 3G3070-CF sends a heartbeat test transmission to the supervising station every 24 hours.
- Each communication path will be monitored for integrity (DACT will have line monitoring enabled and 3G3070-CF and TL300/TL300CF will have cellular/IP network connection supervision enabled). <sup>1 & 2</sup>
- 3G3070-CF is not able to support connection of two DACT outputs from a CFAP with integrated dual dialer.

## What does a 3G3070-CF and T-Link TL300/TL300CF offer for your installation?

Feature	3G3070-CF	TL300/TL300CF
Communication Channel	HSPA (3G) fall-back to EDGE/GPRS	LAN/WAN network or the Internet
Sole Communication Path	Yes (with Supervision)	Yes (with Supervision)
Backup Communication Path	Yes	Yes
Data Plan Requirement	Yes <sup>1</sup>	No <sup>2</sup>
24 hour Protection from Power Failure	Yes	Yes <sup>3,4</sup>
Full Reporting	Yes	Yes
4 Zone Input	Yes	Yes
Programming	(Connect 24)	Keypad / Software
Router Programming	No	Yes
Enclosure	Included	Included
Supervisory Time	300 Seconds	300 Seconds
Heartbeat Signals	97 Seconds	10 Seconds
Mains Connection	120 VAC Required	120 VDC Required <sup>4</sup>

1. When used as a sole communicator, the 3G3070-CF will use the 4 MB rate plan available from C24 Communications. Please contact your C24 Communications master reseller (Central Station) for pricing.
2. Uses existing customer Internet connection for the TL300/TL300CF.
3. Unit continues to work but connection dependent on customer's Internet connection.
4. TL300/TL300CF uses battery backup and power from fire panel.

# Wiring Diagrams

## Sole Communicator Configuration | Module Wiring Diagram for the 3G3070-CF

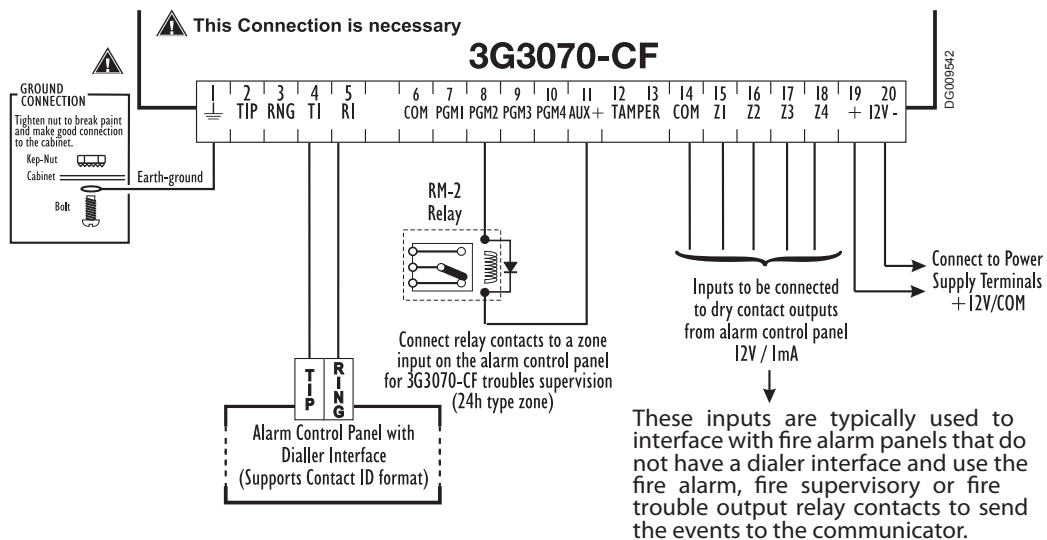

## Sole Communicator Configuration | Module Wiring Diagram for the TL300/TL300CF

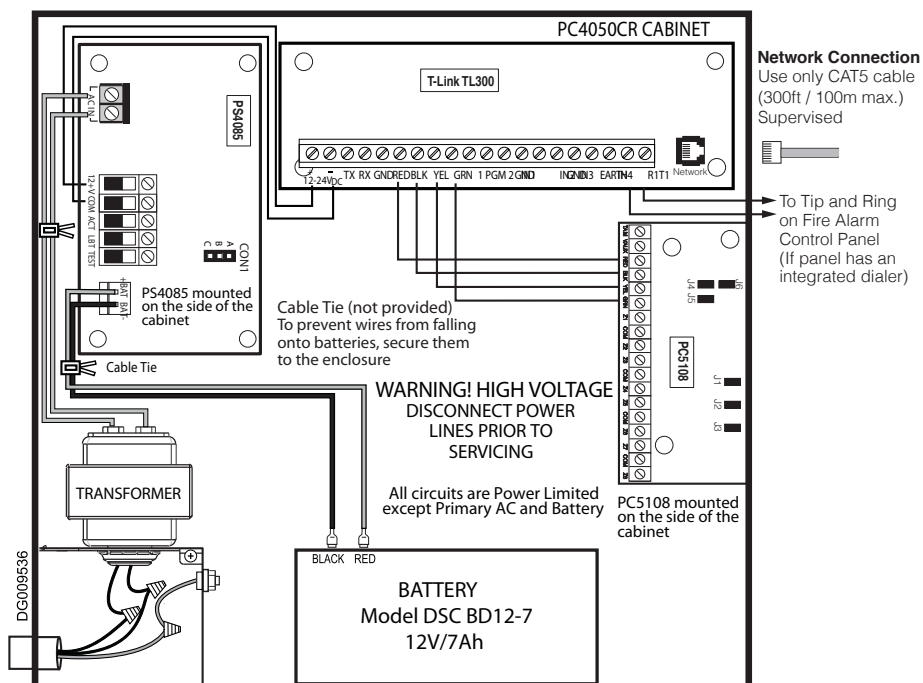

## Power Supply Wiring Diagram | 3G3070-CF and TL300/TL300CF

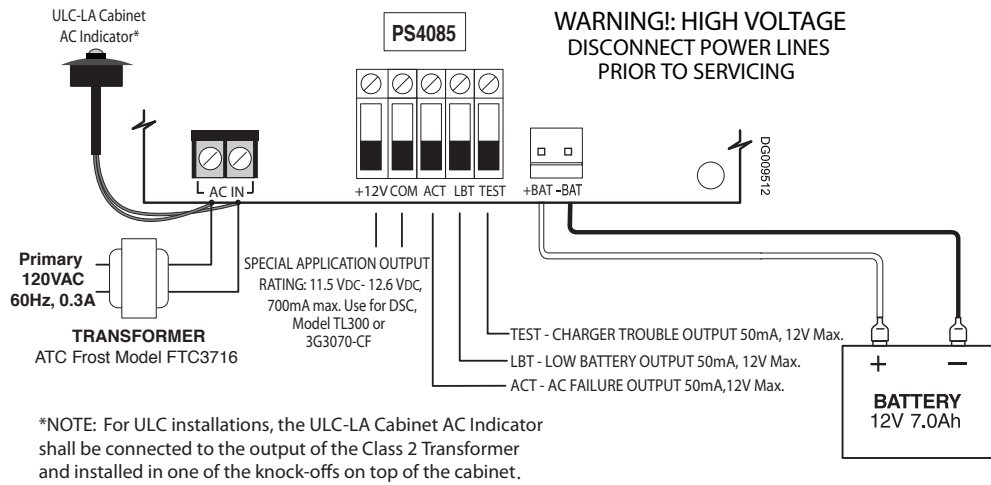

## Telephone connection | 3G3070-CF and TL300/TL300CF

(Not required when 3G3070-CF and T-LINK TL300/TL300CF are used as a stand-alone devices)

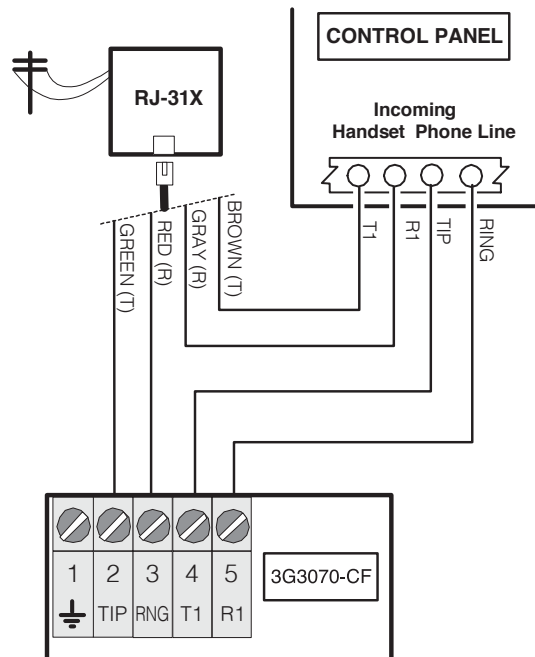



# Frequently Asked Questions

## How reliable are the communication paths given that these units can be used as sole communicators?

The 3G3070-CF and the TL300/TL300CF are built to be robust enough to be used as sole communicators and can withstand most network issues or network congestions. They use the “constant connection” feature of cellular networks and the Internet to communicate heartbeats to the central station every couple of seconds. If the unit fails to communicate its presence in a given time window, the receiving station is alerted with an account absent message. This feature is called “Account Supervision”.

## What happens if there is a power failure?

Because modern cellular networks continue to work during a local power outage, the 3G3070-CF is not affected by power outages and will continue to work for 24 hours following any such outage. TL300/TL300CF also continues to work during a local power outage. However, you need to ensure that the routers in the TL300/TL300CF that are connected at your premises, have 24 hour power backup.

In the unlikely event that power goes out, and the power backup built into these units fails to operate, the supervising station will see a network absent message.

## How does supervision work?

- In order to monitor the communication path, the 3G3070-CF sends a heartbeat signal every 97 seconds to the supervising station. The TL300/TL300CF sends a heartbeat every 10 seconds. These are the default values and may be changed by the installer if required.
- If the receiver misses three consecutive heartbeats within a 300 second window, an “Account Absent Message” is generated at the supervising station. The receiver must then receive 2 consecutive heartbeats to restore the condition.

*Note: It is recommended that the procedure for responding to such messages by the supervising station are established/discussed with the owner of the protected premises.*

## What programming information do I need to setup these units?

- For the TL300/TL300CF you will need the following information:
  - Account Number <sup>4</sup>
  - Receiver IP <sup>4</sup>
  - Receiver port <sup>4</sup>
- For Static IP Addresses Only:
  - IP address <sup>5</sup>
  - Subnet mask <sup>5</sup>
  - Gateway <sup>5</sup>
  - Port 3060 and port 3061 on the router must be open for alarm communication for remote programming
  - Setup TCP port 3064 forwarding on router (please refer to router manual/manufacturer for details)
- For the 3G3070-CF, you will need the following information:
  - Account Number <sup>4</sup>
  - Receiver IP <sup>4</sup>
  - DNIS <sup>4</sup>

<sup>4</sup> - Please contact you supervising (central) station to obtain

<sup>5</sup> - Please contact your local network operator to obtain

## Can I power the TL300/TL300CF from a fire panel?

The TL300/TL300CF may be powered from a 12VDC to 24VDC on a fire panel. However, you will need to ensure that panel battery is sufficient to provide 24 hour backup.

## How can I test if I have installed the unit correctly? How can I test for AC trouble, low battery trouble, and network trouble?

### AC trouble and low battery trouble:

- Remove the AC power
- Panel should show zone trouble (Remember to ensure the AC Power/Low Battery Outputs from the Power Supply (PS4085) are connected to the fire panels zone inputs)

### Network trouble:

- Remove Network cable for TL300/TL300CF and/or remove antenna connector for 3G3070-CF
- Fire panel should show trouble light and the supervising station should show loss of connection within 300 seconds

*Note: Please make sure to always connect the battery first when powering up the units.*

## How can I troubleshoot these devices?

Please refer to the installation manual for troubleshooting instructions.

## What are the supervising station requirements for these products?

The TL300/TL300CF/3G3070-CF work with the following supervising station receivers:

- **A System I** (Firmware version 1.0 and higher current version is 1.12)
- **A System II** (Firmware version 1.1 and higher current version is 2.02)
- **A System III** receiver with 1 DRL3-IP line card (Firmware version 1.91 and higher)
- **A System IV** receiver with DRL4-IP line card (Firmware 1.0 and higher)

## Are there any specific Fire Panel compatibility requirements?

For full communication, the Fire Alarm Control Panel (FACP) must be able to communicate in DTMF Contact ID format and have a zone available for connection to the PS 4085 power supply trouble outputs to show trouble on the fire alarm control panel. The TL300/TL300CF and 3G3070-CF may also connect to the FACP if outputs for alarm, trouble and supervisory from the FACP are available.

## Can I install the two phone lines from the panel in parallel into these units?

Please note that these units are designed to take only one phone line input. Do not install the second phone line in parallel. You should disable the second phone line in the panel. Please contact your panel manufacturer for more details on how to disable the second phone line. These products will not operate correctly if two or more DACT's lines are connected to the R-1/T-1 terminals of the Cellular/IP communicator. There should only be a single pair connected between R-1/T-1 of the Cellular/IP Communicator to the Ring/Tip of the DACT respectively, with no additional lines connected in parallel.



### **What additional parts can I order separately?**

TL300/TL300CF

- Zone Expander (PC5108)

3G3070-CF

- Dual band antenna with extension wire:  
GS-15' Antenna (GS-15ANT), GS-25' Antenna (GS-25ANT), GS-50' Antenna (GS-50ANT)

### **Can these units be installed in the Fire Panel enclosures?**

No. These units come with their own enclosure and cannot be installed inside other fire panel enclosures. Please ensure that all cabinets are installed as per the UL Standards.

## Appendix A: NFPA72 2010 Compliance

Criteria	NFPA72 2010 Edition Requirements	3G3070-CF Compliance	T-Link TL300/TL300CF Compliance
FCC approval when applicable.	Yes	FCC ID: F53113G3070	N/A
Conform to NFPA70, National Electrical Code.	Yes	UL Listing UOXX.S4019. Compliant with UL864 9th Edition (uses hardwired transformer installed in the earth grounded enclosure).	UL Listing UOXX.S4019. Compliant with UL864 9th Edition (uses separately listed power supply).
Monitoring for integrity of the transmission and communications channel.	Monitor for integrity or provide backup channel tested as below.	Heartbeat transmitted by the 3G3070-CF to the Supervising Station (use SG-System I, II, III or IV UL listed receiver) every 97 seconds.	Heartbeat transmitted by the T-Link TL300/TL300CF to the Supervising Station (use SG-System I, II, III or IV UL listed receiver) every 10 seconds.
Annunciate, at the supervising station, the degradation and restoration of the transmission or communications channel.	Within 5 minutes (can use a second separate path to report failure).	If the Alarm Receiver (SG-System I, II, III, IV) used at the Supervising Station does not get the heartbeat within the programmed supervision window of 5 minutes an "Account Absent" alarm message is generated by the receiver.	If the Alarm Receiver (SG-System I, II, III, IV) used at the Supervising Station does not get the heartbeat within the programmed supervision window of 5 minutes, an "Account Absent" alarm message is generated by the receiver.
Redundant communication path where a portion of the transmission or communications channel cannot be monitored for integrity.	Provide a redundant path if communication failure not annunciated at supervising station.	The HSPA network is a redundant network within itself.	The Internet/Intranet is a redundant network within itself.
Interval testing of the backup path(s).	If backup path required, test path once every 24 hours on alternating channels, testing each channel every 48 hours.	Not applicable if supervision window is set to 5 minutes.	Not applicable if supervision window is set to 5 minutes.
Annunciation of communication failure or ability to communicate at the protected premises.	Systems where the transmitter at the local premises unit detects a communication failure before the supervising station, the premises unit will annunciate the failure within 5 minutes of detecting the failure.	Local visual and/or audible trouble is generated at the protected premises when the cellular network is lost (Yellow LED is turned ON and PGM4 output is also activated). The PGM4 output is connected to an input on the Fire Control Panel in order to annunciate visually and audibly the trouble condition at the user interface. Trouble condition annunciation within 90 seconds after detection of loss of communication.	Local visual and/or audible trouble is generated at the protected premises when the IP communication channel is lost. The PGM output is connected to an input on the Fire Control Panel in order to annunciate visually and audible the trouble condition at the user interface. Trouble condition annunciation within 90 seconds after detection of loss of communication.
Time to restore signal-receiving, processing, display, and recording equipment.	Where duplicate equipment not provided, spare hardware required so a repair can be effected within 30 minutes. Complete set of critical spare parts on a 1 to 5 ratio of parts to system units or a duplicate functionally equivalent system unit for every five system units.	Not applicable, this is a requirement for Alarm Receiving equipment.	Not applicable, this is a requirement for Alarm Receiving equipment.

Criteria	NFPA72 2010 Edition Requirements	3G3070-CF Compliance	T-Link TL300/TL300CF Compliance
Loading capacities for system units and transmission and communications channels.	512 independent alarm systems on a system unit with no backup. Unlimited if you can switch to a backup in 30 seconds. The system must be designed such that a failure of a transmission channel serving a system unit must not result in the loss in the ability to monitor more than 3000 transmitters.	The SG-System I, II, III, IV can handle 512 supervised accounts. SG-System III and SG-System IV are capable of fully redundant configurations.	The SG-System I, II, III, IV can handle 512 supervised accounts. SG-System III and SG-System IV are capable of fully redundant configurations.
End-to-end communication time for an alarm.	90 seconds from initiation of alarm until displayed to the operator and recorded on a medium from which the information can be retrieved.	All messages exchanged between protected premises and supervising station using the cellular network average 10-12 second transmission time. Product is UL 864 listed and ULC-S559 (meets 60 second transmission time).	
Record and display rate of subsequent alarms at supervising station.	Not slower than one every 10 additional seconds.	Not applicable, this is a requirement for Alarm Receiving equipment.	Not applicable, this is a requirement for Alarm Receiving equipment.
Signal error detection and correction.	Signal repetition, parity check, or some equivalent means of error detection and correction must be used.	The proprietary communication protocol used by DSC in 3G3070-CF communicator is including checksum verification and synchronization of sequence.	The proprietary communication protocol used by DSC in T-Link TL300/TL300CF communicator is including checksum verification and synchronization of sequence.
Path sequence priority.	No need for prioritization of paths. The requirement is that both paths are equivalent.	Not applicable for single technology type of communicators.	Not applicable for single technology type of communicators.
Carrier diversity.	When a redundant path is required, the alternate path must be provided by a public communication service provider different from the primary path where available.	Not applicable for single technology type of communicators.	Not applicable for single technology type of communicators.
Throughput probability.	When the supervising station does not regularly communicate with the transmitter at least once every 200 seconds, then the throughput probability of the alarm transmission must be at least 90% in 90 seconds, 99% in 180 seconds, 99.999% in 450 seconds.	The throughput probability is ensured by the periodic heartbeat transmission (end to end communication). The heartbeat rate is once every 97 seconds.	The throughput probability is ensured by the periodic heartbeat transmission (end to end communication). The heartbeat rate is once every 10 seconds.
Unique premises identifier.	If a transmitter shares a transmission or communication channel with other transmitters, it must have a unique transmitter identifier.	Every 3G3070-CF installed at the protected premises is uniquely identified by an Account Code.	Every T-Link TL300 /TL300CF installed at the protected premises is uniquely identified by an Account Code.

Criteria	NFPA72 2010 Edition Requirements	3G3070-CF Compliance	T-Link TL300/TL300CF Compliance
Unique flaws.	From time to time, there may be unique flaws in a communication system. Unique requirements must be written for these unique flaws.	Network operators can schedule maintenance work that can possibly disrupt the service availability at certain times.	Internet Service Provider can schedule maintenance work that can possibly disrupt the service availability at certain times. Use reliable ISP providers with back-up servers and proper routers capable to prevent denial of service attacks, spoofing, etc.
Signal priority.	If the communication methodology is shared with any other usage, all alarm transmissions must preempt and take precedence over any other usage. Alarm signals take precedence over supervisory signals.	3G3070-CF can only be used for Fire and Burglary alarm transmissions (no calls or any other application possible with this device). The HSPA (3G) technology presents a better usage of the network resources in terms of delivering the data.	The broadband connection at the protected premises can be shared. The data used for alarm messages is very small so the bandwidth is not affected by the traffic incurred for sending alarms/supervisory or trouble signals to the supervising station. This is an installation specific requirement and it is not influenced by the equipment.
Sharing communications equipment on premises.	If the transmitter is sharing on-premises communications equipment, the shared equipment must be listed for the purpose (otherwise the transmitter must be installed ahead of the unlisted equipment).	Not applicable, the 3G3070-CF connects directly to the Cellular Network.	The Modem/Hub or Router used for the communication channel at the protected premises shall be UL60950 Listed (ITE Equipment).



# Clarifications on NFPA72 2010 Edition verbiage Communication Methods covered under Section 26.6.3

The requirements for general communication methods in Section 26.6.3.1 cover all communications methods between the protected premises and the supervising station that differ from DACT, Two-Way Radio and One-Way Private Radio Equipment. Equipment that meets the performance requirements of this section are permitted as suitable communications methods.

The specific requirements for general communications are also detailed in the table (see pages 10-12). This table defines that annunciations on the degradation and restoration of a communications path must occur within five (5) minutes (if a single communication technology is used). It also defines the fact that equipment conforming to 26.6.3.1 must only provide a redundant path (multiple communications technologies) if the communication failure on a single path cannot be annunciated within five (5) minutes at the supervising station.

Sections 26.6.3.2 and 26.6.3.3 define requirements for specific communication methods identified as DACTS or Two-Way Radio and One-Way Private Radio Equipment. These requirements are not applicable to other transmission technologies like the ones used by 3G3070-CF or T-Link TL300/TL300CF because these products are not using dial up connections and also are not using private radio networks as means for communication with supervising stations.

## Appendix B: UL Listing Guide

**ONLINE CERTIFICATIONS DIRECTORY**

---

**UOXX.S4019**  
**Control Unit Accessories, System**

[Page Bottom](#)

---

**Control Unit Accessories, System**

[See General Information for Control Unit Accessories, System](#)

**DIGITAL SECURITY CONTROLS, DIV OF TYCO SAFETY PRODUCTS CANADA LTD** S4019  
95 BRIDGELAND AVE  
TORONTO, ON M6A 1Y7 CANADA

**End of line resistors**, Model(s) EOLR-1, EOLR-2, EOLR-3

**Fire alarm communicator for central station service fire alarm - commercial: Ethernet/Internet communicator (Other Transmission Technologies) signaling devices**, Model(s) T-Link TL250, T-Link TL300, T-Link TL300 CF, suitable for use as a single communications technology (no need for two phone lines) when supervision heartbeat is enabled and window of supervision at supervising station is set for 5 minutes. Also suitable for use as a multiple communications technologies when used in conjunction with another type of communicator (for example a back-up dialer (DACT) over the telephone line). In this configuration the two communication methods used shall supervise each other and failure of each channel shall be annunciated at the supervising station within 24h (c).

**Fire alarm communicator for central station service fire alarm - commercial: RF communicator (GSM-GPRS network/Other Transmission Technologies) signaling devices**, Model(s) GS3055-I CF, 3G3070-CF suitable for use as a single communications technology (no need for two phone lines) when supervision heartbeat is enabled and window of supervision at supervising station is set for 5 minutes. Also suitable for use as a multiple communications technologies when used in conjunction with another type of communicator (for example back-up to a dialer (DACT) over the phone line). In this configuration the two communication methods used shall supervise each other and failure of each channel shall be annunciated at the supervising station within 24h (c).

(c) - For use with separately Listed compatible control units with integral or Listed remote DACT or as a standalone/sole communicator (no need for two phone lines) as indicated in the installation instructions.

[Last Updated](#) on 2011-12-23

---

[Questions?](#)[Print this page](#)[Terms of Use](#)[Page Top](#)

© 2012 UL LLC

When the UL Leaf Mark is on the product, or when the word "Environment" is included in the UL Mark, please search the [UL Environment database](#) for additional information regarding this product's certification.

The appearance of a company's name or product in this database does not in itself assure that products so identified have been manufactured under UL's Follow-Up Service. Only those products bearing the UL Mark should be considered to be Listed and covered under UL's Follow-Up Service. Always look for the Mark on the product.

UL permits the reproduction of the material contained in the Online Certification Directory subject to the following conditions: 1. The Guide Information, Designs and/or Listings (files) must be presented in their entirety and in a non-misleading manner, without any manipulation of the data (or drawings). 2. The statement "Reprinted from the Online Certifications Directory with permission from UL" must appear adjacent to the extracted material. In addition, the reprinted material must include a copyright notice in the following format: "© 2012 UL LLC".

Approvals:

3G3070-CF NYC Fire Department Certificate of Approval #6083; 3G3070-CF CSFM Listing No. 7300-1273:134; T-Link TL300/TL300CF CSFM Listing No. 7300-1273:135

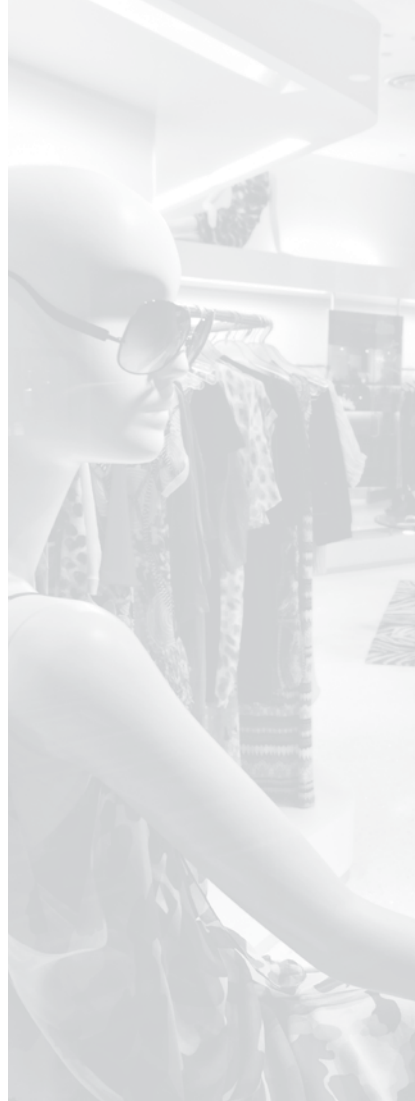

For more information on the products featured here or on any other DSC products please contact:

**1 905.760.3000 | 1 888.888.7838** (Toll-free in United States & Canada)

E-mail: [info@dsc.com](mailto:info@dsc.com)

or contact your DSC Account Representative.

Please visit us at [www.dsc.com](http://www.dsc.com)